

INSTALLATION • MAINTENANCE • OPERATION

PACKAGED REFRIGERATION SYSTEM

Updated May 2023



HTPG2303IOMPRS
P/N: 08537801

CONTENTS

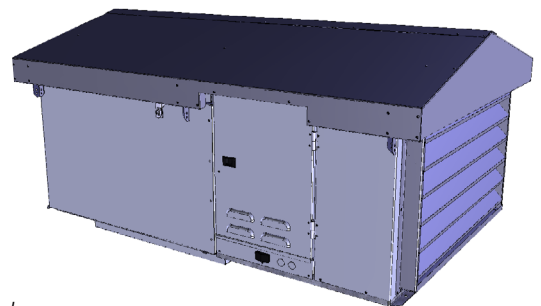
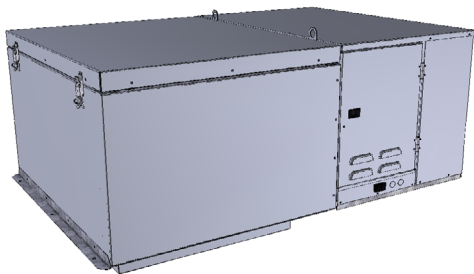

*Due to continuing product development,
specifications are subject to change without notice.*

INSPECTION

Check all items against the bill of landing to make sure all crates or cartons have been received. If there is any damage, report it immediately to the carrier and file a claim. Make sure the voltage on the unit nameplate agrees with the power supply available.

GENERAL SAFETY INFORMATION

1. Installation and maintenance are to be performed only by qualified personnel who are familiar with this type of equipment.
2. Make sure that all field wiring conforms to the requirements of the equipment and all applicable national and local codes.
3. Avoid contact with sharp edges and coil surfaces. They are potential injury hazards.
4. All power sources must be disconnected prior to any servicing or maintenance of this unit. After disconnecting power, allow 5 minutes for capacitor discharge before servicing motors.
5. Refrigerant recovery devices must be used during installation and service of this equipment. It is illegal for ALL refrigerants to be released into the atmosphere.

UNIT PLACEMENT REQUIREMENTS

See dimensions and weight tables on pages 9-11 and follow these guidelines:

1. Make sure that the structural integrity of the box can withstand the weight of the unit(s).
 2. Do not remove the shipping skid from the unit until it is ready to be lifted into place on top of the walk-in.
 3. Do not locate the evaporator section of the unit over a door.
 4. The unit supply air pattern must cover the entire walk-in.
 5. Leave one unit width between sides of unit and walls. Leave two-unit widths between units.
 6. Provide adequate space at the compressor compartment end of the unit and a minimum of two feet above the unit for servicing.
 7. Adequate airflow must be available for condenser. Do not shield the PRS unit, use top of walk-in for storage, or install the PRS unit in a non-ventilated space. Lack of attention to this detail will cause poor performance and possibly unit failure.
 8. Do not locate unit around steam, hot air or fume exhausts.
 9. Indoor units are designed for use in areas that range in temperature from 50°F to 110°F.
 10. Outdoor installation requires a Roof Kit or condensate drain heater. Roof Kit sold separately.
 11. Do not install units in noise sensitive areas. Units must be properly supported to prevent excessive noise and vibration.
 12. Installations that do not conform to all the requirements in this manual will void the unit warranty
-

INSTALLATION INSTRUCTIONS

INDOOR MODELS

GENERAL

Installation and maintenance are to be performed by qualified personnel who are familiar with local codes and regulations. Installers should have previous experience with commercial refrigeration equipment.

i CAUTION: AVOID CONTACT WITH SHARP EDGES AND COIL SURFACES. THEY ARE POTENTIAL HAZARDS.

The PRS cabinet units have lifting eyes. Use a spreader bar when rigging to prevent damage and to reduce stress on the unit cabinet.

IMPORTANT: The compressor compartment cover must be left on units when lifting using the lifting eyes.

1. Inspect packaging for shipping damage. Open package and inspect unit for concealed damage.
2. Follow Figure 1 requirements on page 5.
3. Cut a finished opening in the box ceiling to the dimensions shown in the footprint drawings on page 5. Make sure that the top with the cut-out has the structural integrity to hold the unit. See table on page 10 for unit weights.
4. Make sure that the surface of the box is clean and level where the unit gasket will seal around the opening.
5. Refer to the walk-in box manufacturer's instructions for any procedures that may be necessary to ensure the integrity of the exposed foam in the panels.
6. Make sure the unit is mounted level - no more than 1/8-inch drop per foot.
7. Place the unit into the provided opening with the evaporator air flow directed toward the door (See Figure 1 on page 5). Be careful not to damage the grill during installation.
8. Make sure that the condenser air flow is not obstructed.
9. On indoor units, condensate is evaporated by a discharge line loop run through the drain pan under the compressor, so a drain line is not required. In high moisture environments, the condensate should be drained to a sink or floor drain using flexible tubing.
10. Install the trim pieces around the inside opening.

INSTALLATION & CLEARANCES

INDOOR MODELS

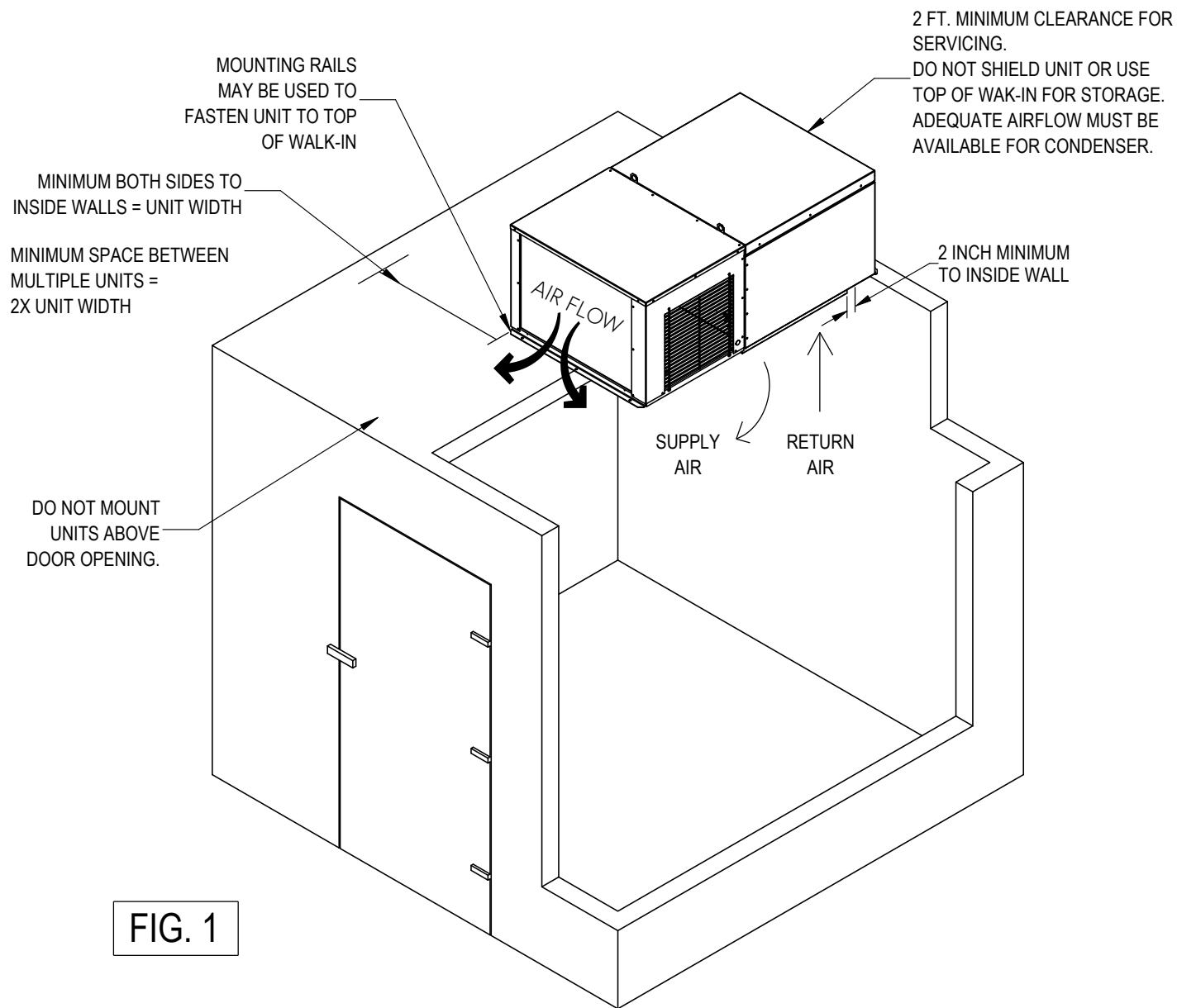

NOTE: Units are ONLY designed for top mount applications

INSTALLATION INSTRUCTIONS

OUTDOOR MODELS

GENERAL

Installation and maintenance are to be performed by qualified personnel who are familiar with local codes and regulations. Installers should have previous experience with commercial refrigeration equipment.

i CAUTION: AVOID CONTACT WITH SHARP EDGES AND COIL SURFACES. THEY ARE POTENTIAL HAZARDS.

The PRS cabinet units have lifting eyes. Use a spreader bar when rigging to prevent damage and to reduce stress on the unit cabinet.

IMPORTANT: The compressor compartment cover must be left on units when lifting using the lifting eyes.

Installation is the same as indoor models except as follows:

1. Units must be curb mounted (curb provided by others). To help with curb sizing, see pages 8-9 which show unit footprint dimensions for each cabinet size. Curb height should be limited to 6 inches. The curb should be insulated and divide supply and return air flows.
2. Make sure curb is level and properly flashed to prevent water leakage into walk-in.
3. Water from rain or snow may get into compressor section of unit. Make sure the curb under this part of unit is designed with openings so water will not collect inside the curbing.
4. The condensate drain outlet is located on the side of the unit. Field piping may be connected to the outlet provided it is adequately sloped and heated to prevent freezing, where necessary. The drain line in the unit is trapped.
5. Secure unit to curb using the base mounting rail.
6. Install roof kit and optional condenser hail guard.

NOTE: Roof membrane (supplied by others) must be cut to allow for evaporator air flow from the unit into the cooled environment (box).

INSTALLATION & CLEARANCES

OUTDOOR MODELS

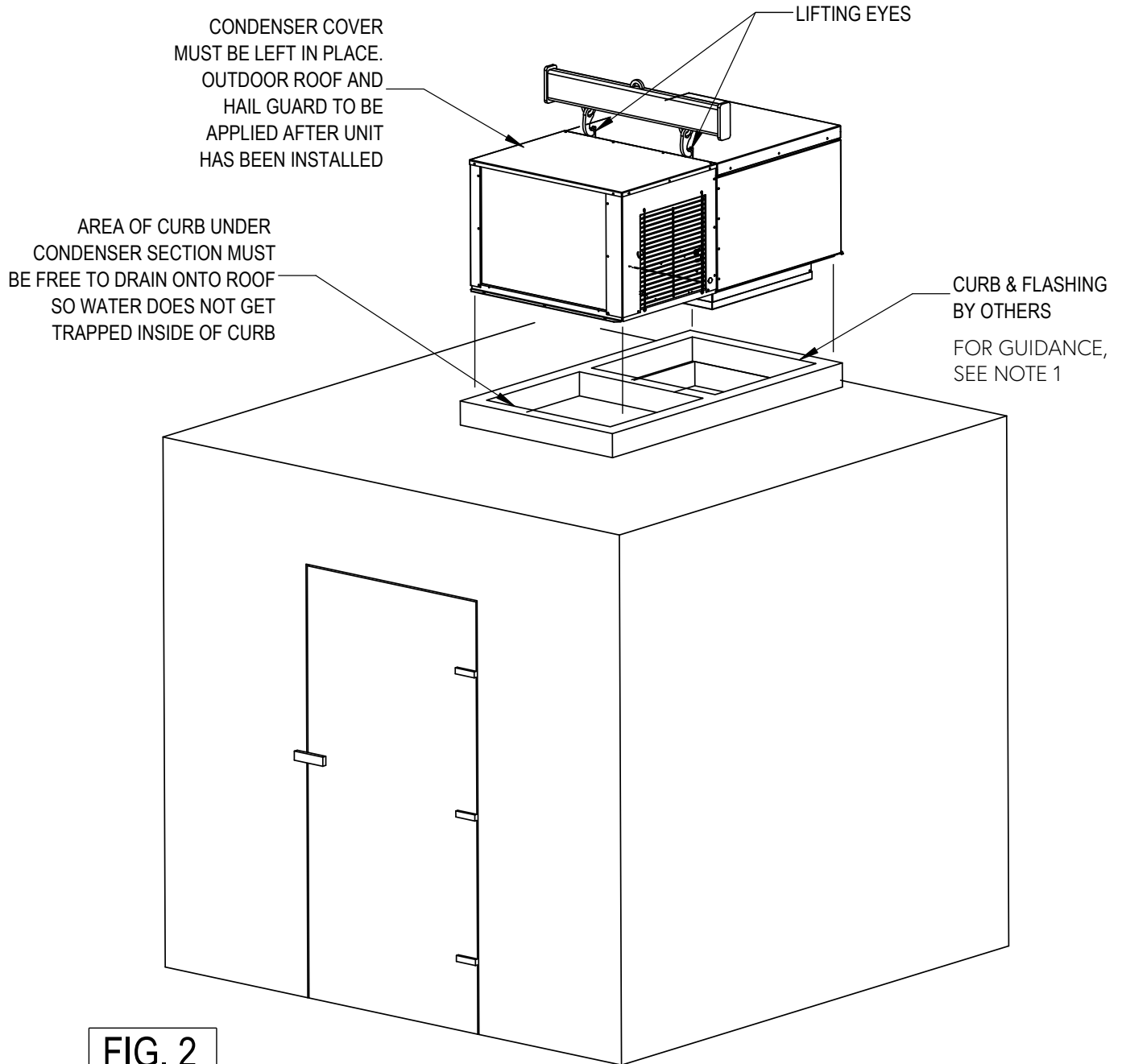

NOTE: Units are ONLY designed for top mount applications

INSTALLATION INSTRUCTIONS

ROOF KIT

PACKAGE CONTENTS

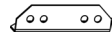
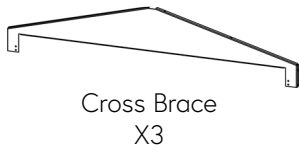

Mounting Bracket
X6

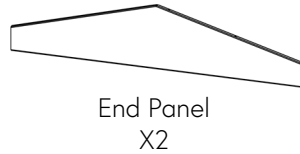
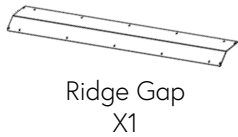

Screws
X72
+ X4 extra
= 76 total

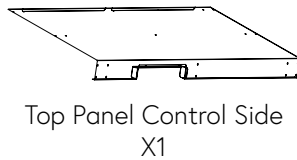
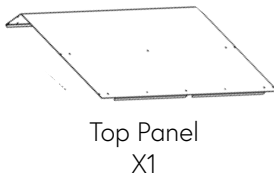

REQUIRED FOR ASSEMBLY
NOT INCLUDED IN CONTENTS



Drill



1/4" Nut Driver



Safety
Glasses



Gloves

FOR BEST RESULTS, FIND A LEVEL AND STABLE AREA TO WORK.

STEP 1

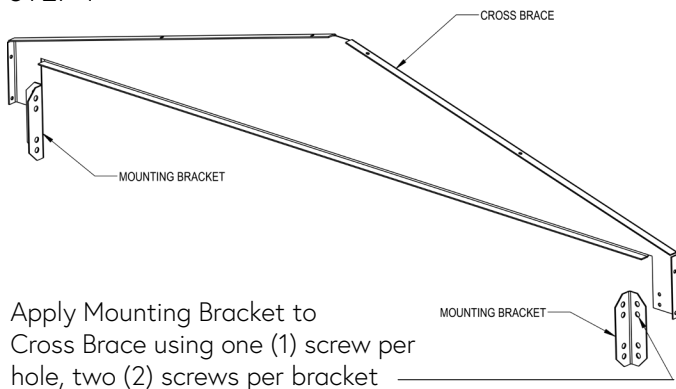

STEP 2

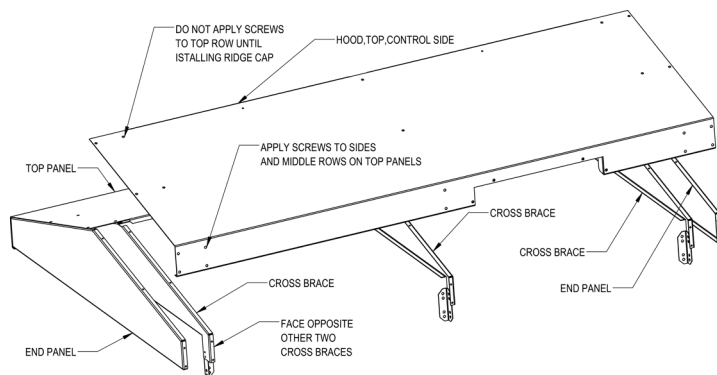
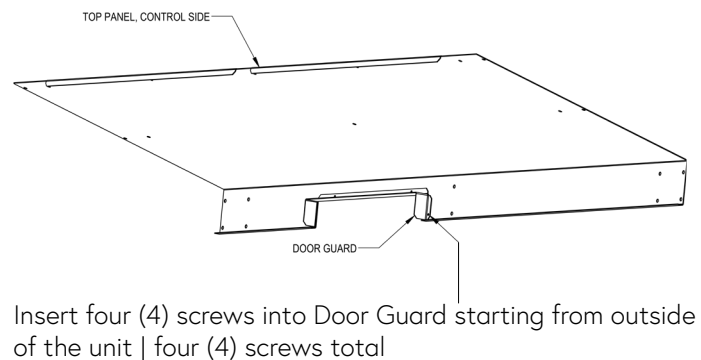

STEP 3

1. For ease of assembly, start with roof upside down
2. Apply side screws on both sides | ten (10) on each side, twenty (20) total screws
3. Flip roof over and apply the screws to middle rows | ten (10) total screws

Continued on next page...

STEP 4

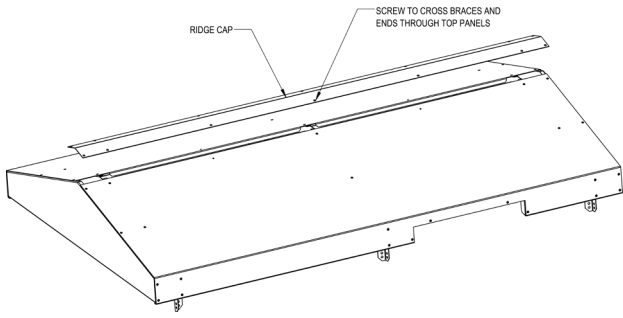

1. Apply two screws to each end of Ridge Cap | four (4) total screws
2. Apply the remaining screws in each of the open holes | ten (10) total screws

STEP 5

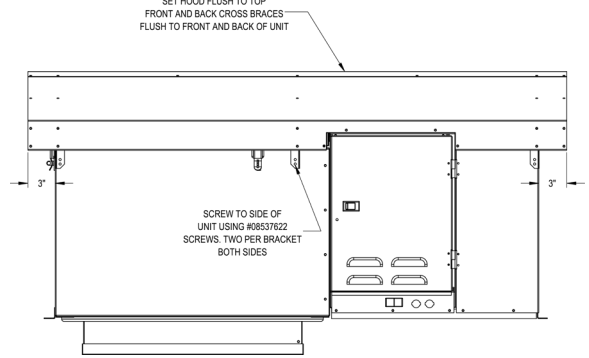

1. Set hood flush to top, front, and back cross braces as well as flush to front and back of unit.
2. Using the bracket holes on each side, screw hood to side of unit using two (2) per bracket, twelve (12) total screws

INSTALLATION & CLEARANCES

HAIL GUARD

PACKAGE CONTENTS

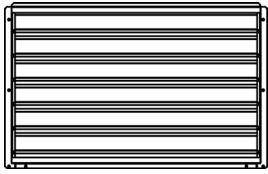

Hail Guard
X1



#10 X 5/8" SCREW
X8

1. Remove screws from front of unit. Screws are aligned vertically down each side (three (3) per side, six (6) total)
2. Place Hail Guard with top flange under cabinet lid and align holes on each side. Replace screws (three (3) per side, six (6) total)
3. Add 2 screws at the bottom into unit base. Screws will align on the inside of vertical screws just placed in previous step.

REQUIRED FOR ASSEMBLY NOT INCLUDED IN CONTENTS



Drill



Safety
Glasses



Gloves



1/4" Nut
Driver

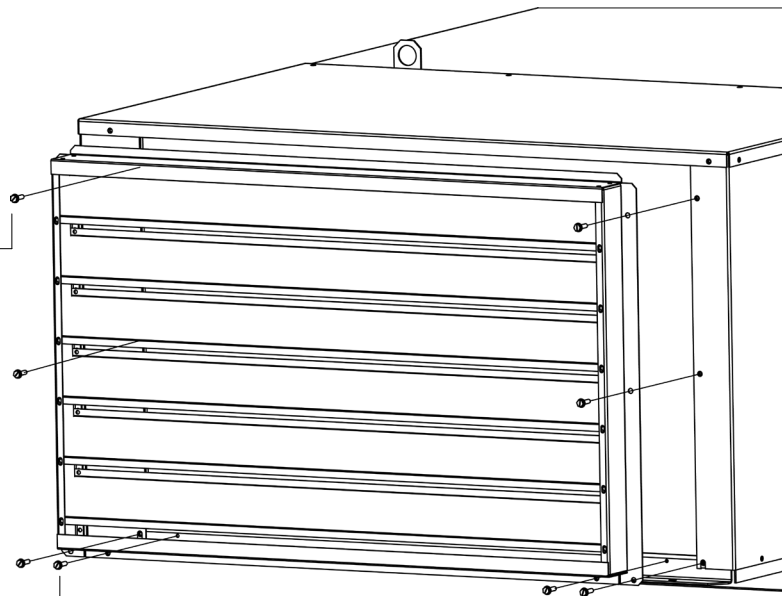

CLEARANCES & UNIT PLACEMENTS

LARGE CABINET DIMENSIONS

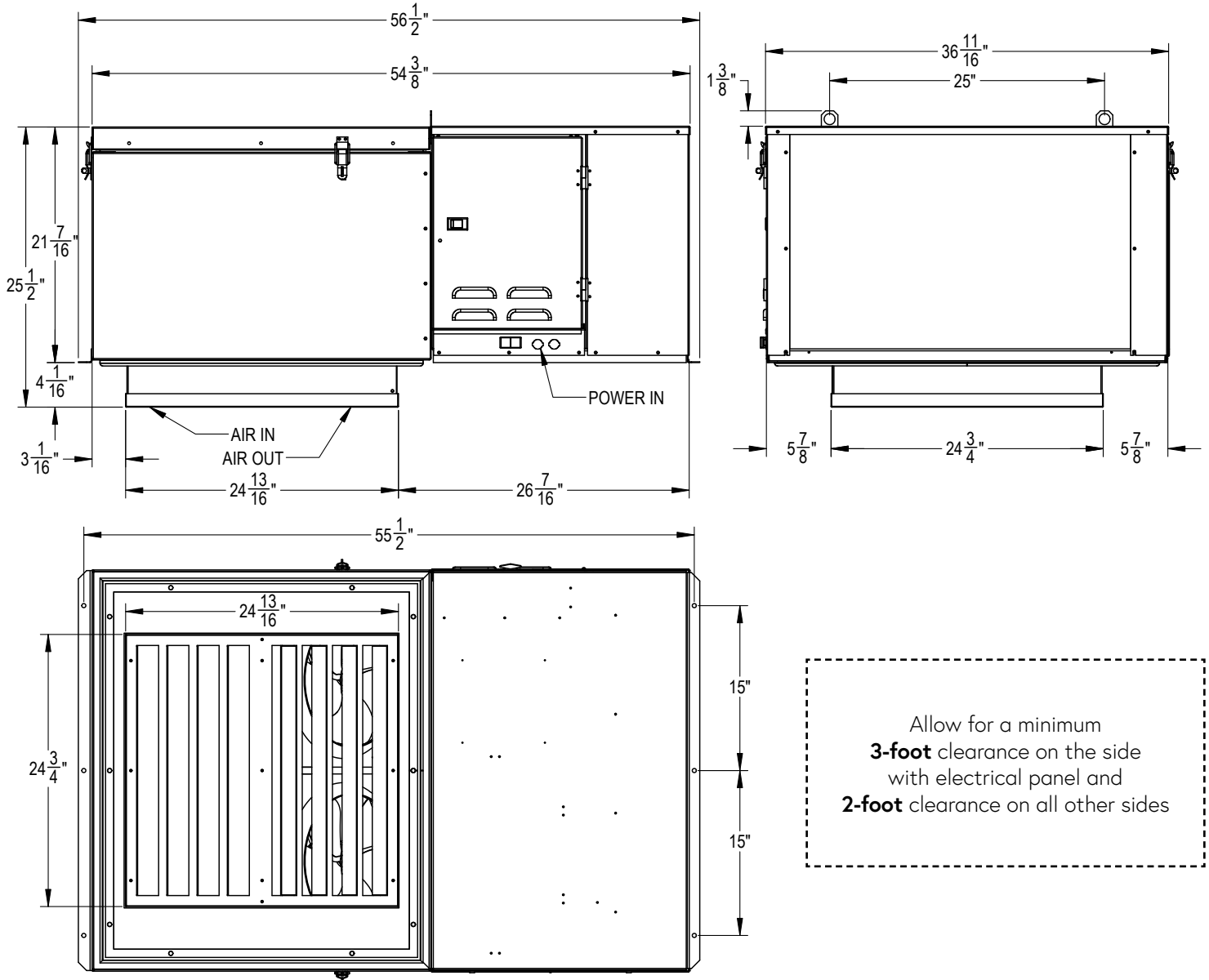

CLEARANCES & UNIT PLACEMENTS

SMALL CABINET DIMENSIONS

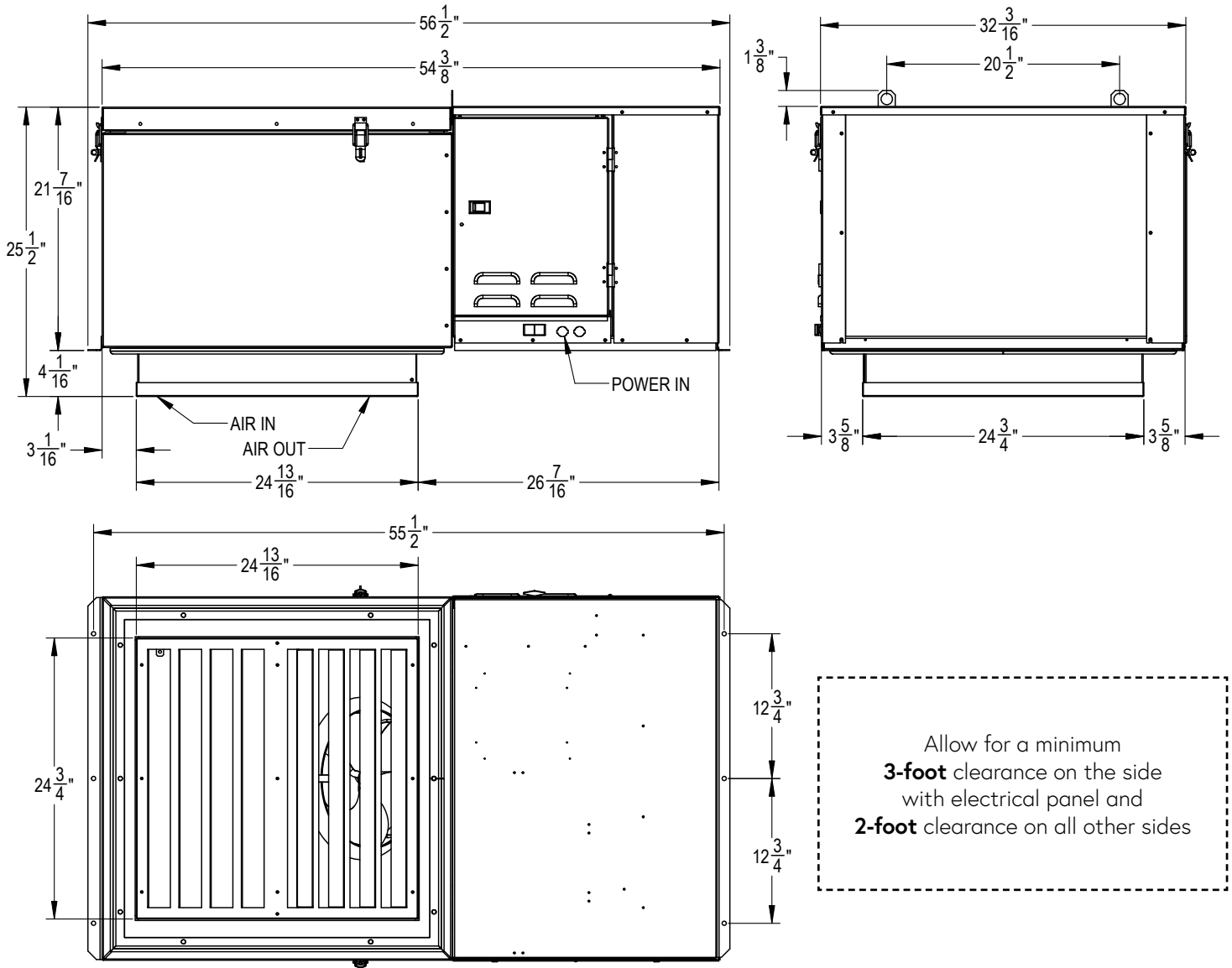

BEFORE UNIT START-UP

1. Check all mechanical and electrical connections for looseness that may have developed during transit and tighten as necessary.
2. Adhere to all applicable building and electrical codes when wiring unit.
3. Make sure supply power is correct voltage and phase for unit and is fused properly.
4. If unit is supplied with a power cord, plug unit into power supply.

IMPORTANT

- ✘ Do not use extension cords to connect unit to power!
- ✘ Plug-in to grounded three prong outlet!
- ✘ Do not remove grounding prong!
- ✘ Do not use a power adapter!

5. If unit is not offered with a cord, hard wire to power suitable supply.

AFTER UNIT START-UP

1. To protect the compressor (in the event of a brief power interruption), the electronic controller is programmed for a five-minute start-up time delay.
2. See EcoNet Controller Operation section to set box temperature (factory settings are 35°F for air defrost coolers, and -10°F for freezers) and change any control parameters that may have to be adjusted to fit the application.
3. Unit defrosting operation should be checked after start-up and periodically thereafter. The amount and pattern of frosting can vary greatly. Frost build-up is dependent on the temperature of the room, the type of product being stored, and usage profile.

PRS WEIGHT

	Model	Cabinet Size	APX. NET WEIGHT		APX. SHIP WEIGHT	
			LB	KG	LB	KG
MEDIUM TEMP	HPH050M48AA	Small	206	93.4	286	129.7
	HPH055M48AA	Small	206	93.4	286	129.7
	HPO080M48AA	Small	206	93.4	286	129.7
	HPO100M48AA	Small	206	93.4	286	129.7
	HPO120M48AA	Large	235	106.6	313	142
	HPH050M48DA	Small	206	93.4	286	129.7
	HPH055M48DA	Small	206	93.4	286	129.7
	HPO080M48DA	Small	206	93.4	286	129.7
	HPO100M48DA	Small	206	93.4	286	129.7
	HPO120M48DA	Large	235	106.6	313	142
	HPO150M48DA	Large	235	106.6	313	142
LOW TEMP	HPO150L48DA	Small	218.5	99.1	298.5	135.4
	HPO250L48DA	Small	218.5	99.1	298.5	135.4
	HPO300L48DA	Large	264	119.7	342	155.1
	HPO350L48DA	Large	264	119.7	342	155.1

ACCESSORY WEIGHT

Part #	Item	APX. NET WEIGHT	
		LB	KG
08537285	LRG ROOF KIT	24.5	11.1
08537289	SM ROOF KIT	21.6	9.8
08537411	SM SNOW GUARD	4.3	1.9
08537412	LRG SNOW GUARD	4.9	2.2

MAINTENANCE

The following items should be checked every six months. Make sure all power is shut off to unit before performing any maintenance or service.

1. Tighten all electrical connections.
2. Check all wiring and insulators.
3. Check contactor for proper operation.
4. Check all fan motors. Tighten motor mount screws/nuts and fan set screws.
5. Clean the condenser and evaporator coil surfaces.

CAUTION: Avoid contact with sharp edges and coil surfaces. They are potential hazards.



6. Check the operation of the control system. Make sure all safety controls are operating properly.
7. Make sure evaporator is defrosting properly.
8. Clean the drain pan and drain lines. Check the drain pan and drain line for proper drainage.
9. On outdoor units make sure the crankcase and drain line heaters, and thermostat are functioning properly.
10. On low temperature units make sure drain line heater is operating properly.

SERVICE

All service to the evaporator section is performed by removing the top panel. The PRS uses an EEV controlled by the EcoNet Controller. Drain pan and defrost heaters on electric defrost models are retained with clips and can be removed for service. The electrical compartment is accessed by the lift off hinged door. The compressor and condenser fans are serviced by removing the condenser section top panel. The PRS unit is factory charged with R448A.

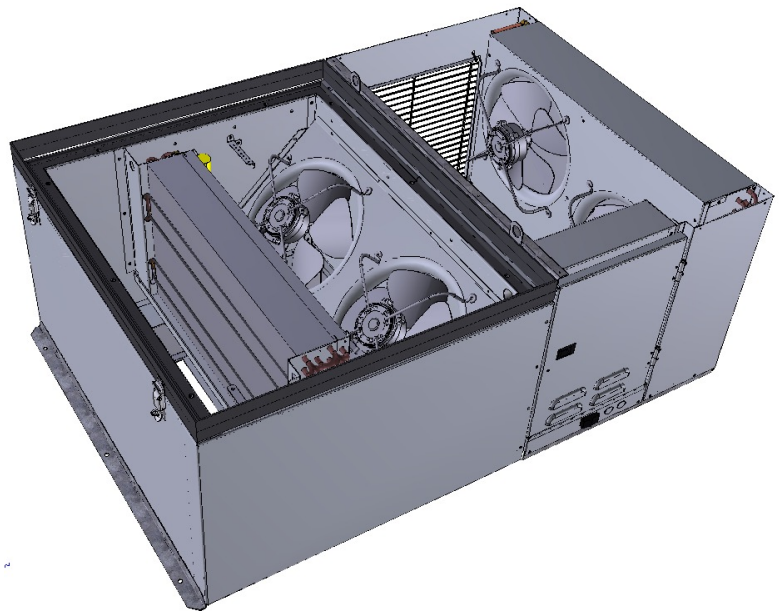

REFRIGERANT CHARGE

	Model	Compressor	Published Charge (lbs)
MEDIUM TEMP	HPH050M48*A	RST40C1E	2.7
	HPH055M48*A	RST45C1E	2.7
	HPO080M48*A	ZB06KAE	2.7
	HPO100M48*A	ZB07KAE	2.7
	HPO120M48*A	ZB08KAE	2.9
	HPO150M48*A	ZS11KAE	3.4
LOW TEMP	HPO150L48*A	ZF05KAE	2.7
	HPO250L48*A	ZF07KAE	2.7
	HPO300L48*A	ZF09K4E	3
	HPO350L48*A	ZF11K4E	3

As part of our commitment to quality, continuing analysis will be performed regularly. This data is confirmed as of April 2023.

SEQUENCE OF OPERATION

Set the rocker switch by the access panel to the ON position to power up the EcoNet controller.

COOLING

On start-up, the controller will zero the Electronic Expansion Valve (EEV) and turn on Aux Relay 1 to start the evaporator fans.

After 1 minute, if the Space Temperature is greater than the Setpoint + Setpoint Control, the controller will begin a cooling cycle and the EEV will open. The controller will maintain an active cooling cycle for a minimum of 5 minutes by default (configurable via Settings→Equipment→Cmp. Min. Run Time).

With the EEV open, the Suction Pressure will begin to increase. When the Suction Pressure is greater than the Cut-Out Setpoint + Cut-In Offset, the controller will turn ON Aux Relay 2 to start the compressor and the condenser fans.

1. If the condensing pressure is below 120 PSIG, the fan speed control switch (FS) will close causing the condenser fans to operate at low speed.
2. If the condensing pressure rises above 180 PSIG the fan speed control switch (FS) will open causing the condenser fans to operate at high speed.

Immediately after the compressor starts, the Suction Pressure will temporarily decrease as the controller starts metering the EEV to seek balanced system operation.

The evaporator fans (Aux Relay 1) will turn ON when Evap Temp 1 drops below 35°F (Freezer) or 55°F (Cooler).

When the EEV is open, the controller will ignore the low pressure Cut-Out Setpoint for the first 60 seconds of compressor (Aux Relay 2) operation. This bypass period is to prevent any possible unwanted low pressure cut-out during the initial decrease in Suction Pressure, and it is only applied on an active cooling cycle while the EEV is open.

After the bypass time has elapsed, if the Suction Pressure drops below the Cut-Out Setpoint, the Aux Relay 2 will turn OFF and stop the compressor. The controller is still in an active cooling cycle with the EEV open, which will cause the Suction Pressure to rise again and turn the compressor (Aux Relay 2) back ON and reset the 60 second bypass timer.

When the Space Temp Setpoint is satisfied, the cooling cycle ends, and the controller will close the EEV causing a pump down. The compressor (Aux Relay 2) will turn OFF when the Suction Pressure drops below the Cut-Out Setpoint.

While the EEV is closed, if the Suction Pressure rises above Cut-Out Setpoint + Cut-In Offset, the compressor (Aux Relay 2) will momentarily turn ON to keep the system pumped down, then immediately turn OFF when Suction Pressure falls below the Cut-Out Setpoint. There is no low pressure bypass timer when the EEV is closed.

SEQUENCE OF OPERATION

DEFROST

FREEZER • Electric Defrost

Default defrost logic is based on cooling run time (default 6 hours; can be adjusted via Settings→Equipment→Def. Cmp. Run Time). Optional alternate defrost logic is Adaptive (Settings→Equipment→Defrost Type). See EcoNet Evaporator Controller Installation Manual for more information on Adaptive Defrost.

When the defrost cycle starts, the controller will close the EEV and wait 1 minute to allow the compressor to pump down before turning on the defrost heaters. (This pump down delay can be adjusted via Settings→Equipment→Def. Pmp. Dn. Delay.)

After this delay, the evaporator fans will turn OFF, and the defrost heaters will turn ON. While the controller is undergoing a defrost cycle ("Defrosting" indicated on the controller display), the compressor will remain OFF.

The defrost termination will occur when Evap Temp 1 reaches 55F (adjustable via Settings→Equipment→Defrost Termination Temp), or when the 1 hour defrost time limit is reached (adjustable via Settings→Equipment→Def. Max Run Time).

When the defrost cycle ends, the controller will allow a 5-minute Drain Time with the EEV still closed and evaporator fans turned off. At this time, if the Suction Pressure has risen above the Cut-Out Setpoint + Cut-In Offset, the compressor (Aux Relay 2) will be allowed to momentarily turn on if needed to keep the system pumped down. When the Drain Time ends, the controller will open the EEV to begin the next cooling cycle.

COOLER • Air Defrost

Default defrost logic is based on cooling run time (default 6 hours; can be adjusted via Settings→Equipment→Def. Cmp. Run Time). Adaptive Defrost is not applicable for Cooler (air defrost) setting.

When the defrost cycle starts, the controller will close the EEV to force a pump down and keep the evaporator fans running at low speed after the compressor has turned OFF. While the controller is undergoing a defrost cycle ("Defrosting" indicated on the controller display) the compressor will remain OFF.

The defrost termination will occur when Evap Temp 1 reaches 40F (adjustable via Settings→Equipment→Defrost Termination Temp), or when the 1 hour defrost time limit is reached (adjustable via Settings→Equipment→Def. Max Run Time).

When the defrost cycle ends, the controller will open the EEV to begin the next cooling cycle.

CONTROLLER OPERATION

ECONET

The EcoNet Evaporator Controller on the PRS controls the following:

1. Evaporator fans On/Off via Auxiliary Relay 1.
2. Compressor On/Off via Auxiliary Relay 2, based on Suction Pressure Cut-Out and Offset setpoints.
3. Electronic Expansion Valve (EEV) to control superheat with readings from Suction Temperature sensor and Suction Pressure transducer. EEV will also fully close for system pump down.
4. Defrost (Air or Electric) based on cooling runtime or adaptive defrost algorithms.

NOTES

- Controller version HT-PG01-00-01-23 or newer is required for PRS operation.
- Verify Voltage Selector Switch is set to the correct setting (115V or 230V) before applying power to the unit.

ECONET BOARD

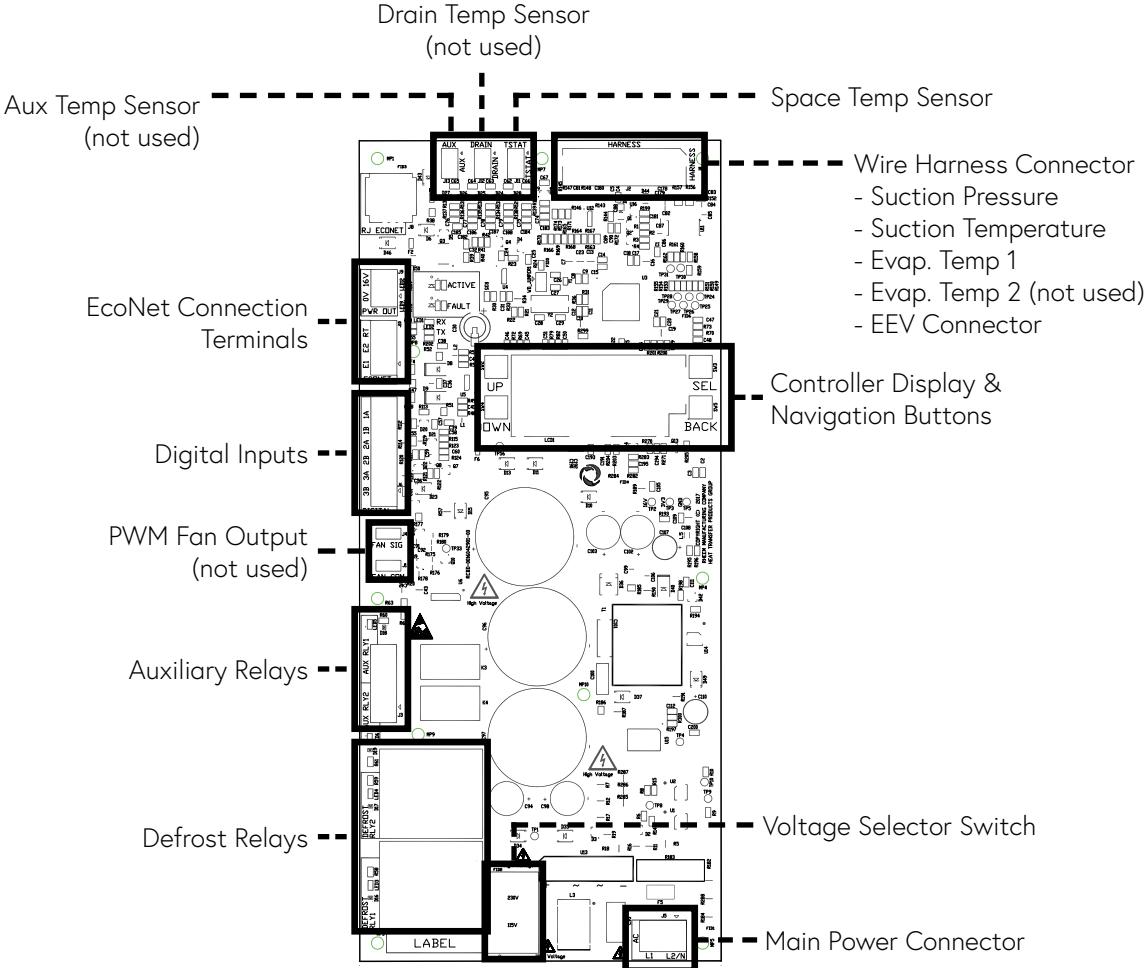

CONTROLLER OPERATION

ECONET



CONTROLLER CONFIGURATIONS FOR PRS OPERATION

Scan QR code to access EcoNet Controller IOM for a complete list of configuration settings

CONFIGURATION PARAMETER	ADJUSTMENT RANGE	DEFAULT SETTING
Aux Relay Config.	Comp-Fan Control; Fan Control	"Comp-Fan Control"
Cut-Out Setpoint	-2 PSIG to 60 PSIG	"0 PSIG" for Freezer units; "20 PSIG" for Cooler units
Cut-In Offset	10 PSIG to 50 PSIG	"20 PSIG"
Def. Pmp. Dn. Delay	None; 1 min; 2 mins; 3 mins; 4 mins; 5 mins	"1 min" for Comp-Fan Control; "None" for Fan Control

CONFIGURATION SETTINGS

Navigate to *Settings*→*Equipment* on controller display to view/adjust:

1. Aux Relay Config.

- Comp-Fan Control:** Controller will use Auxiliary Relay 1 for evaporator fan on/off control, and Aux Relay 2 for compressor on/off control based on Suction Pressure transducer reading. Applicable to PRS. NOTE: PRS MUST be set to Comp-Fan Control or damage to equipment will result!!!
- Fan Control:** Controller will use Auxiliary Relays 1 and 2 to control dual speed fan motors on evaporator. This setting is not applicable for PRS!!!

2. **Cut-Out Setpoint:** Pressure setpoint at which the compressor will turn off.

3. **Cut-In Offset:** Pressure differential for compressor to turn on.

4. **Def. Pmp. Dn. Delay:** Defrost pump down delay for Freezer units; when an electric defrost cycle starts, the controller will wait the specified amount of time after the EEV closes to allow for compressor pump down before turning on the defrost heaters.

With *Aux Relay Config.* set to **Comp-Fan Control**, the EcoNet controller will rely on the Suction Pressure transducer reading to determine when to cycle the compressor ON or OFF via Auxiliary Relay 2.

When a cooling cycle starts, the controller will open the EEV which will cause the Suction Pressure to increase.

The compressor will turn ON when:

Suction Pressure (PSIG) is greater than Cut-Out Setpoint + Cut-In Offset

CONTROLLER OPERATION

ECONET

To prevent compressor short cycling, when a cooling cycle starts (EEV opens) the controller will keep the compressor on for a minimum amount of time even if the Suction Pressure briefly gets below the Cut-Out Setpoint.

When a cooling cycle ends (setpoint is satisfied, defrost starts, etc.), the controller will close the EEV. The compressor running will cause the Suction Pressure to decrease.

The compressor will turn OFF when:

Suction Pressure (PSIG) is less than the **Cut-Out Setpoint**

When there is no call for cooling (EEV is closed), the compressor will turn off immediately whenever the Suction Pressure drops below the Cut-Out Setpoint.

EXAMPLE 1 • Low Temperature Unit

Cut-Out Setpoint = 0 PSIG

Cut-In Offset = 20 PSIG

Compressor will turn ON when Suction Pressure is greater than 20 PSIG.

Compressor will turn OFF when Suction Pressure is less than 0 PSIG.

EXAMPLE 2 • Medium Temperature Unit

Cut-out Setpoint = 20 PSIG

Cut-In Offset = 20 PSIG

Compressor will turn ON when Suction Pressure is greater than 40 PSIG.

Compressor will turn OFF when Suction Pressure is less than 20 PSIG.

NOTE

If the unit is defrosting, the controller will not allow the compressor to turn on. When the unit is not defrosting, the controller will allow the compressor to turn on for the next cooling cycle when the EEV opens, or for pump down if needed while the EEV is closed.

TROUBLESHOOTING GUIDE

MODES OF OPERATION: MEDIUM TEMP

CONTROL CIRCUIT INPUTS										SYSTEM RESPONSE					
Rocker Switch	Cntrl Mode	LP Bypass Timer*	LP Cntrl*	Pmp dwn Delay*	Drain time*	Fan Delay*	HP	FS	HS	Comp	CCH	Cond Fans	Evap Fans	Dr Line Htr	Def Htrs
○	-	-	-	-	-	-	-	-	-	Off	Off	Off	Off	-	-
●	Cooling Active	Bypass	-	-	-	-	●	●	-	On	Off	Slow	Fast	-	-
●	Cooling Active	Bypass	-	-	-	-	●	○	-	On	Off	Fast	Fast	-	-
●	Cooling Active	-	○	-	-	-	-	-	-	Off	On	Off	Slow	-	-
●	Cooling Active	-	●	-	-	-	●	●	-	On	Off	Slow	Fast	-	-
●	Cooling Active	-	●	-	-	-	●	○	-	On	Off	Fast	Fast	-	-
●	Cooling Active	-	-	-	-	-	○	-	-	Off	On	Off	Slow	-	-
●	Cooling Satisfied	-	-	-	-	-	-	-	-	Off	On	Off	Slow	-	-
●	Defrost	-	-	-	-	-	-	-	-	Off	On	Off	Slow	-	-

● Closed

○ Open

NOTE

- "-" implies that the feature is either not applicable or that the feature does not affect this mode of operation.
- Control inputs identified with * are on board the EcoNet 1.0 controller.

TROUBLESHOOTING GUIDE

MODES OF OPERATION: LOW TEMP

CONTROL CIRCUIT INPUTS										SYSTEM RESPONSE					
Rocker Switch	Cntrl Mode	LP Bypass Timer*	LP Cntrl*	Pmp dwn Delay*	Drain time*	Fan Delay*	HP	FS	HS	Comp	CCH	Cond Fans	Evap Fans	Dr Line Htr	Def Htrs
○	-	-	-	-	-	-	-	-	-	Off	Off	Off	Off	Off	Off
●	Cooling Active	Bypass	-	-	-	-	●	●	-	On	Off	Slow	Fast	-	-
●	Cooling Active	Bypass	-	-	-	-	●	○	-	On	Off	Fast	Fast	-	-
●	Cooling Active	-	○	-	-	-	-	-	-	Off	On	Off	Slow	-	-
●	Cooling Active	-	●	-	-	-	●	●	-	On	Off	Slow	Fast	-	-
●	Cooling Active	-	●	-	-	-	●	○	-	On	Off	Fast	Fast	-	-
●	Cooling Active	-	-	-	-	-	○	-	-	Off	On	Off	Slow	-	-
●	Cooling Satisfied	-	○	-	-	-	-	-	-	Off	On	Off	Slow	-	-
●	Defrost	-	●	Pmp dwn	-	-	●	●	-	On	Off	Slow	Fast	Off	Off
●	Defrost	-	●	Pmp dwn	-	-	●	○	-	On	Off	Fast	Fast	Off	Off
●	Defrost	-	○	Delay	-	-	-	-	-	Off	On	Off	Slow	Off	Off
●	Defrost	-	○	-	-	-	-	-	●	Off	On	Off	Off	On	On
●	Defrost	-	○	-	-	-	-	-	○	Off	On	Off	Off	Off	Off
●	Defrost	-	○	-	Delay	-	-	-	-	Off	On	Off	Off	Off	Off
●	Cooling Active	Bypass	-	-	-	Delay	●	○	-	On	Off	Slow	Off	Off	Off
●	Cooling Active	Bypass	-	-	-	Delay	●	●	-	On	Off	Fast	Off	Off	Off

● Closed

○ Open

ELECTRICAL WIRING DIAGRAMS

LOW TEMP ELECTRIC DEFROST 208-230/1



SCAN QR CODE FOR PACKAGE UNIT IOM

LEGEND	FACTORY WIRING	FIELD WIRING
CH CONTACTOR	---	---
CCH CRANK CASE HEATER	---	---
FSS FAN SPEED SWITCH	---	---
GRD GROUND	---	---
HP HIGH PRESSURE CONTROL	---	---
HS HEATER SAFETY	---	---
IS LIQUID INJECTION SOLENOID MOTOR	---	---
M# POTENTIAL RELAY	---	---
R# RELAY	---	---
RC RUN CAPACITOR	---	---
SC START CAPACITOR	---	---
TB TERMINAL BOARD	---	---

NOTE:
ALL WIRES ARE 14 AWG
UNLESS OTHERWISE SPECIFIED.

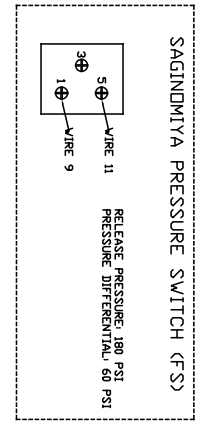
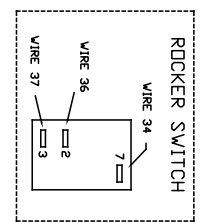
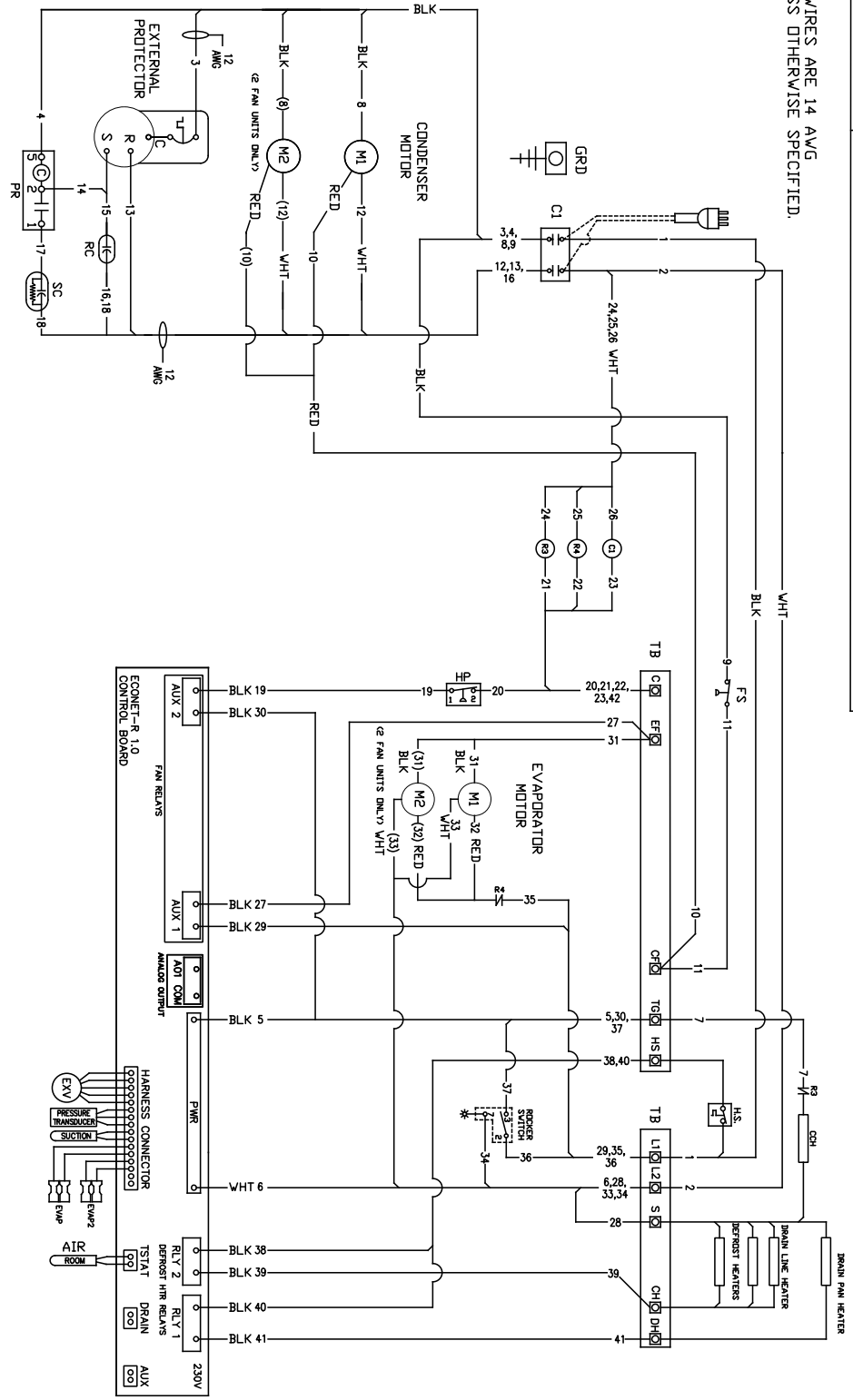

08536922P

PIPING DIAGRAMS

MEDIUM TEMP

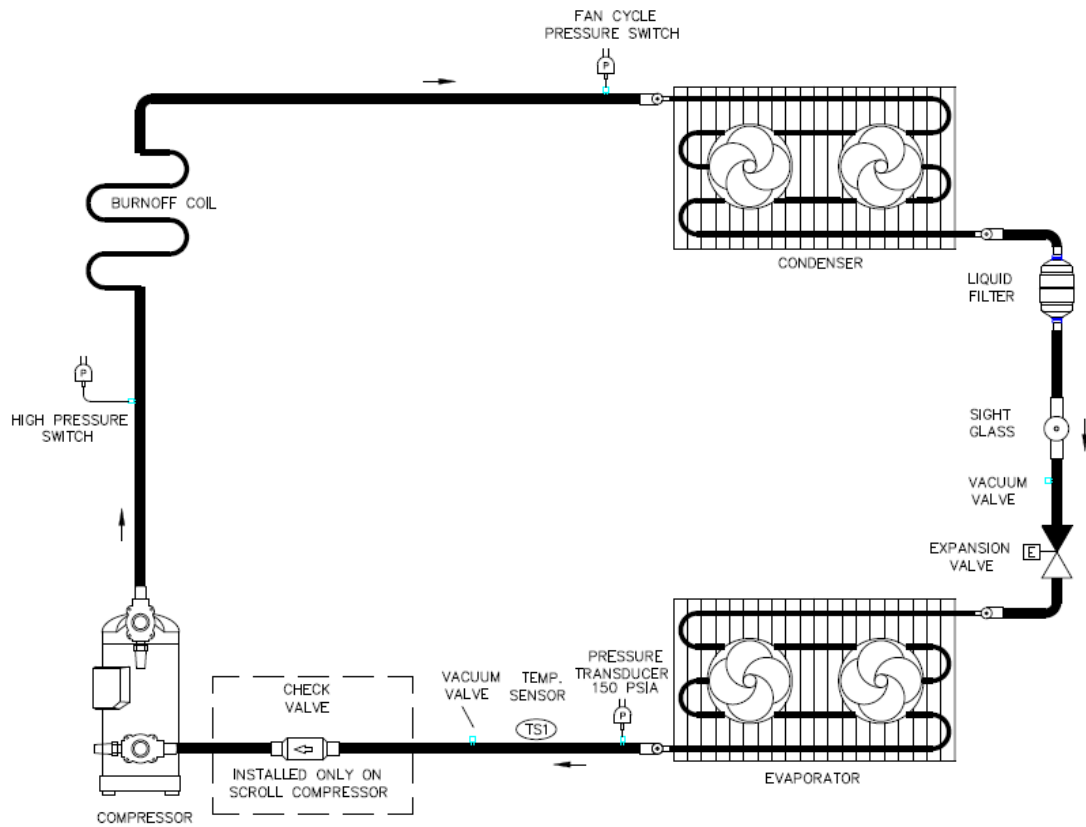

LOW TEMP

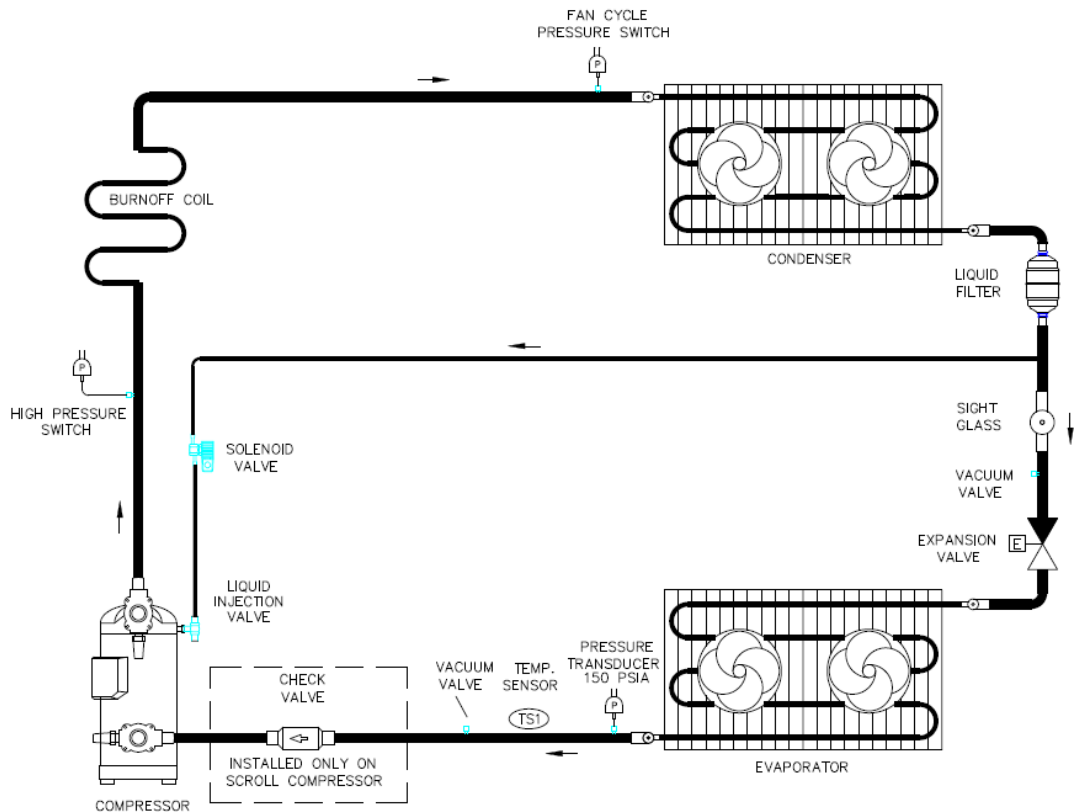

REPLACEMENT PARTS

Below is list of common replacement parts. Should you need something outside of this list, please call our Parts Team at 1-855-HTPARTS (1-855-487-2787) or email Parts@htpg.com.

DESCRIPTION	PART NUMBER (P/N)
A3-40-525-12 SLIDE LATCH	08323272
LATCH,APEX,#8335-02	08326021
EVAP BOX,GASKET,LG CAB,PKG UNIT	08536858
EVAP BOX,GASKET,#X2199,SM CAB,PKG UNIT	08537151
MOTOR,35W,EC,115/230,2SP,NIDEC	08216216
FAN,PROP,12-24X1/4,CW,AL,ECM	08221175
GRILLE,WIRE,BLACK,16.88X15.75	08397064
MOUNT,MOTOR,WIRE,12IN,4 LEG	08397068
PRESSURE TRANSDUCER,0-150 PSIA	08219621
SPACE TEMP THERMISTOR ASSEMBLY, 10KOHMS - ECONET	08219623
CONTROL BOARD, REFRIGERATION	08219624 
EVAP TEMP, FLUSH MOUNT THERMISTOR,10K OHM - ECONET	08219636
EEV,SER-AA-3X4 ODF,NOCBL	08219543
EEV,SER-A-3X4 ODF, NOCBL	08219544
EEV,SER-B-3X4 ODF,NOCBL	08219540
SWITCH,HI PRESS,AUTO RESET 400	08219424
CONTROL,PRES,ENCAP,OPEN RISE,180PSIG	08537183

 Controller version HT-PG01-00-01-23 or newer is required for PRS operation

SHIPPED LOOSE ACCESSORIES

The roof kit and hail guard are shipped loose, field assembled, and installed. Sizes are available for both cabinets.

DESCRIPTION	REPLACEMENT P/N 08537285	REPLACEMENT P/N 08537289
TOP PANEL	08537286	08537290
TOP PANEL, CONTROL SIDE	08537338	08537336
RIDGE CAP	08537292	08537292
CROSS BRACE	08537287	08537291
END PANEL	08537293	08537313
DOOR GUARD	08537340	08537340
MOUNTING BRACKET	08537288	08537288

WARRANTY

The Seller warrants against defect in materials and workmanship in products which it manufactures for (1) year from the date of installation or up to 18 (eighteen) months from the date of shipment, whichever event occurs first, when properly installed and operated under normal use. This guarantee does not include any labor or other charges made outside of the Seller's factory for replacement or repair of defective parts unless specifically stated in the body of the Seller's invoice. On parts not manufactured by HTPG, such as motors, controls, valves and compressors we extend to the Buyer the same warranties made to us by the manufacturer.

The Seller's only liability under this warranty or otherwise shall be the repair or replacement (at Seller's option) of nonconforming goods or parts. Seller assumes no liability for incidental or consequential damages such as injury to persons or property, or lost profits.

Claims must be submitted to our Warranty Group within 90 days of the repair. To submit a claim, visit <https://www.htpg.com/submit-a-claim/>



ENGINEERED FOR COOL.™

HTPG.com

©2023 Heat Transfer Products Group
Published May 2023
HTPG2303IOMPRS



GET A DIGITAL VERSION OF THE GUIDE
by scanning this QR code or the one
located in the ebox of the unit